

ENVIROFAN

Gold Line

136F-7 277V

Specifications:

Size: 36"
Weight: 17 lbs.
CFM: 12,000
Area: 800 sq. ft.
RPM: 400
Velocity: 650 ft./min.
Amps: .30
Volts: 277V, 60Hz

Safety Cable: 7"
Lead Wires: 20" (from top of bell)

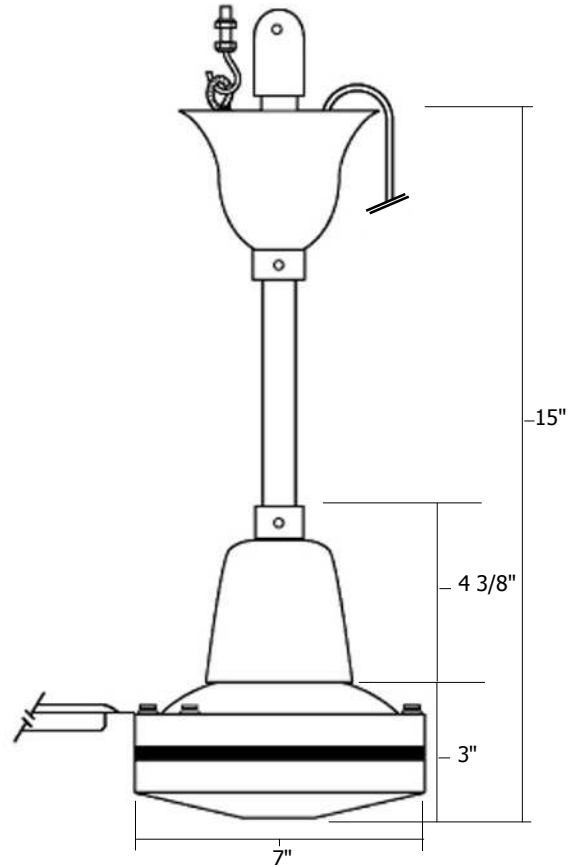

Features:

Thermo Protected Motor
Secondary Support Cable
Cast Iron Motor Housing
Aluminum Blades
UL Listed - Meets all 507 standards
5 year warranty
8" Downrod (3/4" i.d.)



Note:

To reduce risk of injury to persons, install fan so that blades are at least 10 feet above floor
Technical specifications subject to change without notice

Northwest Envirofan

A Division of Northwest Environmental Systems, Inc.

Envirofan Ceiling Fans • Protecto-Guard Ceiling Fan Guards • Fan Controls

800-236-7080

(920) 235-7808

FAX (920) 235-3049