



ALX-UB SERIES - UPBLAST BELT DRIVE SPUN ALUMINUM EXHAUSTERS

Ideal for exhausting air from restaurants, offices, warehouses or commercial buildings. The ALX series spun aluminum exhaust fan can be used as either a roof top or wall mount exhaust fan.

FEATURES

- Spun aluminum housing will not rust, chip or peel.
- Aluminum backward inclined wheel is non-overloading.
- Belt drive.
- For motor options consult our fan selection software Delair. www.canarm.com/delair
- Units up to 24" (max 2HP) can be wall mounted.
- Quick release latches for easy motor access.



UL705 Supplement SC - Power Ventilator for Restaurant Exhaust Appliances certified, refer to our UL705 Supplement SC - Power Ventilator for Restaurant Exhaust Appliances Catalogue page C in *Roof Mount Ventilation* for all installation requirements



Intertek
UL705 POWER VENTILATOR FOR RESTAURANT EXHAUST APPLIANCES

OPTIONS

- Wall mount bracket (for all sizes up to 24")
- Grease collection box (required for restaurant exhaust applications)
- Curb hinge
- Disconnect switches
- Roof curbs
- Other base (curb cap) options available. See C2 in dimensions table.

For use only in non-restaurant applications:

- Motorized damper
- Gravity (automatic) damper
- Bird screen



QUICK RELEASE LATCHES FOR EASY MOTOR ACCESS

DIMENSIONS

NOTE: DUE TO MOTOR MANUFACTURERS VARIANCES IN DESIGN, PLEASE SEE USER MANUAL FOR MOTOR DIMENSIONAL GUIDELINES.

MODEL	DIMENSIONS (INCHES)								Shaft Size	Wheel Diameter	Roof Opening	WEIGHT (lbs) without motors
	A	B	C	C2	D	E	F	G Ø				
ALX135-UB	25.25	32.13	21.00	24.75	17.13	2.00	3.75	0.44	3/4"	13.50	17.00	43
ALX150-UB	26.13	32.13	21.00	24.75	17.13	2.00	3.75	0.44	3/4"	15.00	17.00	45
ALX165-UB	31.13	37.50	24.75	28.00	21.13	2.00	4.00	0.44	3/4"	16.50	20.75	108
ALX180-UB	31.75	37.50	28.00	24.75	21.13	2.00	4.00	0.44	3/4"	18.25	20.75	116
ALX210-UB	36.25	43.75	33.13	40.00	25.50	2.50	4.00	0.44	1"	21.00	29.00	178
ALX245-UB	37.00	43.75	33.13	40.00	25.50	2.50	4.00	0.44	1"	24.50	29.00	183

Note: Net weights for belt drive units do not include motor & drives.

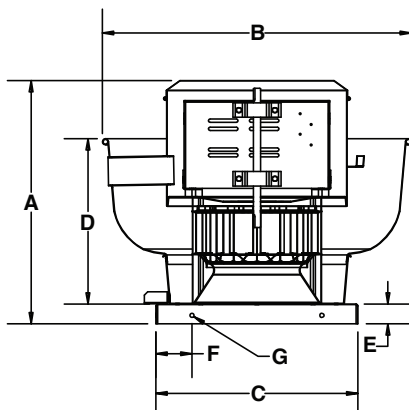

Canarm certifies that the ALX-UB Series shown herein are licensed to bear the AMCA Seal. The ratings shown are based on tests and procedures performed in accordance with AMCA Publications 211 & 311 and comply with the requirements of the AMCA Certified Ratings Programme.

The AMCA certified ratings seal applies to air and sound performance only. The ALX-UB Series shown herein are not approved by AMCA for FEI ratings.



DISCONNECT SWITCHES

- Wire disconnect switches are available. See Controls & Thermostats section for details.



ALX-UB SERIES - UPBLAST BELT DRIVE SPUN ALUMINUM EXHAUSTERS

PERFORMANCE SPECIFICATIONS

ALX UB WITH MOTORS & DRIVES

MODEL	RPM RANGE	HP	RPM	Sones @ 1/2" SP	0" SP				1/2" SP				1" SP				1-1/4" SP				1-1/2" SP			
					CFM	BHP	FEI	FEPact (kW)	CFM	BHP	FEI	FEPact (kW)	CFM	BHP	FEI	FEPact (kW)	CFM	BHP	FEI	FEPact (kW)	CFM	BHP	FEI	FEPact (kW)
SINGLE PHASE AND WIRED DISCONNECT																								
ALX135UBT10025**	862-1293	1/4	1078	8.6	1285	-	-	-	892	-	-	-	-	-	-	-	-	-	-	-	-	-		
ALX135UBT10033**	932-1398	1/3	1260	12.8	1498	-	-	-	1182	-	-	-	-	-	-	-	-	-	-	-	-			
ALX135UBT10050**	1137 - 1574	1/2	1394	16.5	1662	-	-	-	1377	-	-	-	974	-	-	-	-	-	-	-	-			
ALX150UBT10050**	932-1398	3/4	1165	20	1976	-	-	-	1591	-	-	-	-	-	-	-	-	-	-	-	-			
ALX150UBT10075**	1078-1617	3/4	1367	27	2320	-	-	-	2008	-	-	-	1584	-	-	-	1264	-	-	-	-			
ALX150UBT10100	1341-1820	1	1473	31	2502	0.67	0.49	0.68	2225	0.70	0.86	0.71	1846	0.71	1.08	0.72	1612	0.71	1.12	0.72	1262	0.67	1.11	0.68
ALX165UBT10100	1097-1489	1	1379	21	2637	0.73	0.47	0.74	2285	0.80	0.78	0.80	1804	0.83	0.92	0.83	1497	0.83	0.92	0.83	1127	0.77	0.90	0.77
ALX165UBT10150	1254-1646	1 1/2	1608	26	3067	1.15	0.35	1.11	2779	1.25	0.61	1.20	2416	1.28	0.79	1.23	2197	1.30	0.83	1.24	1946	1.31	0.85	1.25
ALX180UBT10100	980-1293	1	1222	25	3402	0.91	0.47	0.90	2984	0.96	0.82	0.94	2429	0.98	1.01	0.96	1961	0.97	0.99	0.95	-	-	-	-
ALX180UBT10200	1097-1489	2	1419	30	3969	1.45	0.35	1.37	3612	1.50	0.64	1.42	3164	1.54	0.83	1.45	2893	1.54	0.89	1.45	2549	1.53	0.92	1.44
ALX210UBT10150	862-1132	1 1/2	1021	21	4771	1.31	0.45	1.25	4172	1.31	0.82	1.25	3387	1.30	1.03	1.24	2785	1.25	1.05	1.20	-	-	-	-
ALX245UBT10150	673-889	1 1/2	775	18.9	5701	1.13	0.59	1.10	4615	1.17	0.98	1.13	2885	1.05	1.09	1.03	-	-	-	-	-	-	-	-
ALX245UBT10200	745-979	2	845	22	6202	1.48	0.50	1.40	5250	1.52	0.87	1.43	3901	1.45	1.05	1.37	2850	1.32	1.02	1.26	-	-	-	-
ALX245UBT10300	862-1132	3	945	28	6954	2.06	0.40	1.90	6103	2.13	0.72	1.96	5046	2.10	0.93	1.93	4375	2.04	0.98	1.88	3442	1.90	0.97	1.76
THREE PHASE WITH NO DISCONNECT																								
ALX150UB30100*	1341-1820	1	1473	31	2502	0.67	0.51	0.66	2225	0.70	0.89	0.69	1846	0.71	1.11	0.70	1612	0.71	1.16	0.70	1262	0.67	1.15	0.66
ALX165UB30100*	1097-1489	1	1379	21	2637	0.73	0.49	0.71	2285	0.80	0.80	0.78	1804	0.83	0.95	0.80	1497	0.83	0.95	0.80	1127	0.77	0.93	0.75
ALX165UB30150*	1254-1646	1 1/2	1608	26	3067	1.15	0.36	1.10	2779	1.25	0.62	1.18	2416	1.28	0.80	1.21	2197	1.30	0.84	1.23	1946	1.31	0.86	1.24
ALX180UB30100*	980-1293	1	1241	25	3402	0.91	0.48	0.87	2984	0.96	0.84	0.92	2429	0.98	1.03	0.94	1961	0.97	1.01	0.93	-	-	-	-
ALX180UB30200*	1097-1489	2	1403	30	3969	1.45	0.35	1.37	3612	1.50	0.64	1.42	3164	1.54	0.83	1.45	2893	1.54	0.89	1.45	2549	1.53	0.92	1.44
ALX210UB30150*	862-1132	1 1/2	1017	21	4771	1.31	0.45	1.24	4172	1.31	0.83	1.24	3387	1.30	1.04	1.23	2785	1.25	1.06	1.18	-	-	-	-
ALX245UB30150*	673-889	1 1/2	790	18.9	5701	1.13	0.60	1.08	4615	1.17	1.00	1.11	2885	1.05	1.11	1.01	-	-	-	-	-	-	-	-
ALX245UB30200*	745-979	2	862	22	6202	1.48	0.50	1.40	5250	1.52	0.87	1.43	3901	1.45	1.05	1.37	2850	1.32	1.02	1.26	-	-	-	-
ALX245UB30300*	862-1132	3	964	28	6954	2.06	0.41	1.86	6103	2.13	0.74	1.92	5046	2.10	0.95	1.90	4375	2.04	1.00	1.85	3442	1.90	0.99	1.73

** 115V only. All other motors will be wired at high voltage.
For three phase motors, substitute "" with "M" for 230/460 volt (wired for 460V) or "P" for 575 volt

ALX UB WITHOUT MOTORS & DRIVES

MODEL	MIN HP	MAX HP	MAX RPM	TYPICAL MAXIMUM CFM @ SP																							
				0" SP				1/2" SP				1" SP				1-1/2" SP				2"				2-1/4"			
				CFM	BHP	FEI	FEPact (kW)	CFM	BHP	FEI	FEPact (kW)	CFM	BHP	FEI	FEPact (kW)	CFM	BHP	FEI	FEPact (kW)	CFM	BHP	FEI	FEPact (kW)	CFM	BHP	FEI	FEPact (kW)
ALX135-UB	-	3/4	1760	2099	0.66	0.44	0.67	1875	0.70	0.75	0.71	1636	0.72	0.97	0.73	1345	0.72	1.09	0.73	-	-	-	-	-	-	-	
ALX150-UB	1/4	1	1641	2789	0.93	0.40	0.92	2536	0.95	0.72	0.93	2239	0.98	0.94	0.96	1845	0.99	1.05	0.97	-	-	-	-	-	-	-	
ALX165-UB	1/4	2	1800	3437	1.63	0.28	1.53	3182	1.73	0.50	1.62	2878	1.78	0.67	1.66	2506	1.81	0.78	1.68	2073	1.83	0.82	1.70	1827	1.81	0.81	1.68
ALX180-UB	1/4	2	1500	4176	1.69	0.32	1.58	3848	1.74	0.59	1.62	3428	1.79	0.77	1.67	2904	1.79	0.89	1.67	2200	1.75	0.89	1.63	1105	1.26	0.77	1.21
ALX210-UB	1/2	3	1300	6070	2.71	0.28	2.45	5618	2.71	0.54	2.45	5100	2.73	0.74	2.47	4472	2.70	0.88	2.44	3577	2.58	0.94	2.34	2879	2.38	0.92	2.17
ALX245-UB	1/2	5	1200	8816	4.15	0.26	3.66	8187	4.30	0.49	3.79	7457	4.34	0.67	3.82	6616	4.31	0.80	3.80	5562	4.16	0.89	3.67	4915	4.03	0.90	3.56

Consult our Delair fan selection software for full fan curves and performance data.
www.canarm.com/delair

* Motor adaptor plate required for 3HP+

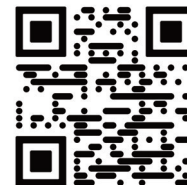

View FEI charts
canarm.com/fei-alex