

# Tube Axial Duct Fans

## MODEL B – TUBE AXIAL DUCT FAN – BELT DRIVE



### APPLICATION

Designed to handle clean dry air to a maximum of 180°F. Ideally suited for removal of fumes in paint spray booths, smoke removal from welding operations or supply air for air make-up systems.

### FEATURES AND BENEFITS

- Long-life maintenance free sealed for life fan bearings.
- Spark-resistant heavy duty cast aluminum propellers.
- Adjustable motor base allows for proper belt tension for maximum belt life.
- Pulleys are rugged cast iron or turned steel.
- Motors are high quality industrial grade available in single or three phase - totally enclosed or explosion proof.

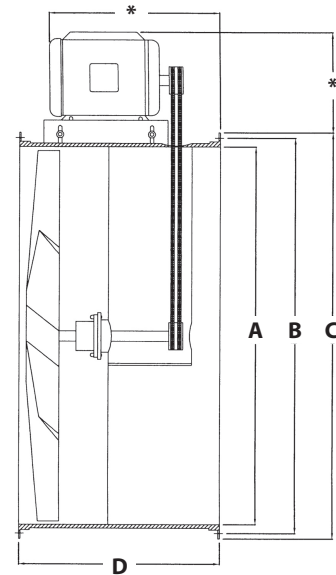
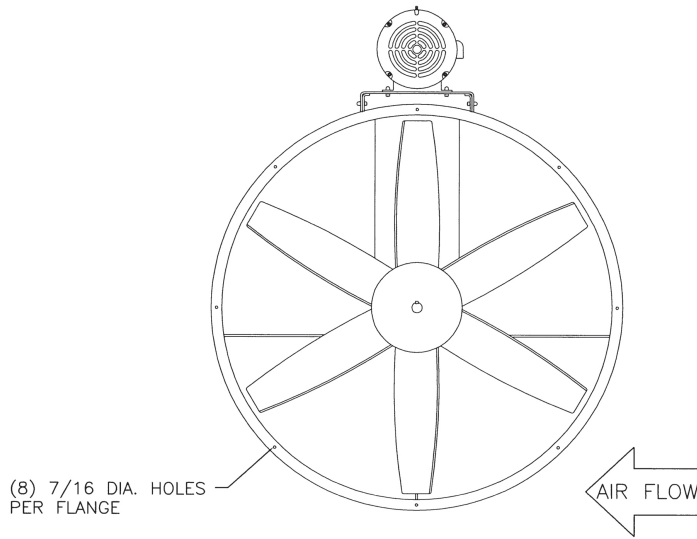

*\*Dimensions vary with motor.*

### DIMENSIONS (subject to change without notice)

MODEL	A	B	C	D	HP
B-12	12"	13 1/8"	14"	12"	1/4-3/4
B-15	15"	16 1/8"	17"	12"	1/4-3/4
B-18	18"	19 1/8"	20"	12"	1/4-1 1/2
B-24	24"	25 3/4"	27"	12"	1/2-1
B-24	24"	25 3/4"	27"	16"	1-3
B-27	27"	28 3/4"	30"	16"	3/4-2
B-30	30"	31 3/4"	33"	16"	1/2-5
B-34	34"	35 3/4"	37"	16"	1 1/2-5
B-36	36"	37 7/8"	39"	18"	3-5
B-42	42"	43 9/16"	45"	18"	1 1/2-5

## MODEL B – TUBE AXIAL DUCT FAN – BELT DRIVE PERFORMANCE DATA

Blade Dia.	Model	Prop	HP	RPM	Free Air	CAPACITY C.F.M.						
						1/8" SP	1/4" SP	3/8" SP	1/2" SP	3/4" SP	1" SP	1-1/4" SP
12"	B-12-1/4	CA101	1/4	2625	1444	1307	1033	638	380	---	---	---
	B-12-1/3	CA101	1/3	2875	1586	1436	1135	700	415	---	---	---
	B-12-1/2	CA101	1/2	3450	1875	1650	1400	1320	1250	1100	660	---
	B-12-3/4	CA102	3/4	3450	2044	1960	1920	1820	1650	1500	1100	---
15"	B-15-1/4	CA103	1/4	2000	2600	2100	1700	---	---	---	---	---
	B-15-1/3	CA103	1/3	2200	2950	2500	2100	1760	1000	---	---	---
	B-15-1/2	CA264	1/2	1890	3350	3000	2650	2200	1500	---	---	---
	B-15-3/4	CA264	3/4	2200	3900	3700	3400	3100	2700	1150	---	---
18"	B-18-1/4	CA235	1/4	1600	3050	2500	2000	1200	---	---	---	---
	B-18-1/3	CA235	1/3	1725	3375	3000	2600	2000	1400	---	---	---
	B-18-1/2	CA235	1/2	1890	3850	3500	3100	2500	2000	---	---	---
	B-18-1	CA107	1	1725	4600	4375	4080	3600	3000	2100	1550	---
24"	B-18-1 1/2	CA107	1 1/2	1990	5350	5060	4830	4550	3950	3000	2500	---
	B-24-1/2	CA144	1/2	1298	5643	5320	4826	4440	3500	---	---	---
	B-24-3/4	CA144	3/4	1600	6906	6510	5900	5440	4650	2750	---	---
	B-24-1	CA144	1	1725	7425	7000	6350	5850	5000	3300	1775	---
	BPR-24-1	CA196	1	1357	7450	7100	6650	5950	5200	3000	---	---
	BPR-24-1 1/2	CA196	1 1/2	1540	8200	7900	7650	7280	6850	5500	---	---
	BPR-24-2	CA196	2	1680	9600	9250	8940	8655	8250	7300	4800	---
	B-24-2	CA191	2	1600	9760	9114	8830	8460	8090	7000	4400	---
27"	B-24-3	CA191	3	1725	10500	9800	9500	9100	8700	7800	5000	3600
	BPR-27-3/4	CA111	3/4	1250	8330	7814	7550	7070	6500	4650	---	---
	BPR-27-1	CA111	1	1400	9400	8675	8480	7950	7300	5200	---	---
	BPR-27-1 1/2	CA111	1 1/2	1600	10700	10250	9700	9080	8375	6000	2500	---
30"	BPR-27-2	CA152	2	1350	11500	11200	10700	10000	9300	8000	5200	---
	B-30-1/2	CA167	1/2	1300	8900	7925	6660	4270	2300	---	---	---
	B-30-1	CA113	1	1298	9897	8970	7980	6050	4120	---	---	---
	BPR-30-1 1/2	CA115	1 1/2	1035	11100	10600	9700	8600	7500	3500	---	---
	BPR-30-2	CA115	2	1176	12100	11660	11000	10121	9322	6700	---	---
	B-30-3	CA115	3	1350	13480	12982	12498	12042	11465	10380	9470	7500
34"	B-30-5	CA115	5	1650	16440	15832	15242	14686	13982	12659	11550	9200
	B-34-1 1/2	CA128	1 1/2	1170	13695	12400	11100	8365	6000	1015	---	---
	B-34-2	CA190	2	1027	14657	13652	12590	11500	10000	8000	---	---
	B-34-3	CA190	3	1175	17580	16750	15896	14600	14095	12000	9500	---
36"	B-34-5	CA190	5	1416	20500	19800	19000	18325	17500	16000	14200	12250
	BPR-36-3	CA198	3	930	17500	16800	15900	14740	14100	12200	---	---
42"	BPR-36-5	CA198	5	1100	20600	19950	19200	18500	17800	16020	14300	---
	BPR-42-1 1/2	CA119	1 1/2	750	18960	17000	14662	11700	7200	---	---	---
	BPR-42-2	CA119	2	820	20700	18900	17002	14700	11400	4000	---	---
	BPR-42-3	CA119	3	890	23700	22100	20200	18960	16970	9950	3600	---
	BPR-42-5	CA199	5	850	26900	25600	24403	23450	22250	18400	13900	---

### OPTIONAL ACCESSORIES

- Belt guard
- Combination motor cover/belt guard
- Companion flanges
- Horizontal support legs
- Horizontal or vertical support brackets
- Inlet or outlet guards – OSHA Compliant
- Inspection door