



S&P USA

Qty:	1
Tag:	
Project:	Explosion Proof Roof Exhaust

STXB14-1/4

Centrifugal Roof Exhauster-Belt Drive Upblast

STANDARD FEATURES:

Heavy Gauge Aluminum Construction • Non-Overloading Aluminum Curved Backward Inclined Wheel • Drives Sized for a Minimum of 150% of Drive Horsepower • Heavy Duty 200,000 Hour Rated Pillow Block Bearings • Quick-Release latches on motor cover for easy access to motor compartment • Lift lugs for easy and safe placement of the fan on the roof • Integral Deep Spun Inlet • Disconnect standard with ODP and TE single speed motors • AMCA Air and Sound Licensed • cULus 705 Certified • 5 Year Fan and 1 Year Motor Warranty •

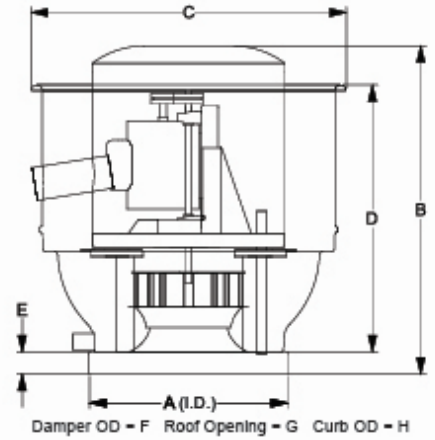

Performance

Fan RPM	Flow (CFM)	SP (in W.G.)	Power (HP)	SE	TE	FPM (TS)	FPM (OV)
1116	2000	.25	.252	31%	42%	4383	1164

Altitude (Feet): n/a Temperature (Fahrenheit): n/a Density (Lb/Ft3): .075

Motor Information: (Wired for 115V)

HP	RPM	Volts/PH/Hz	Enclosure	Efficiency	Mounted
.25	1725	115V/230V/1PH/60HZ	EXPLOSION PROOF	STANDARD	YES

Sound Power Levels - Octave Bands

LwA	DBA	Sone	1	2	3	4	5	6	7	8
70.6	59.1	9.5	67.4	74.4	68.4	66.0	64.4	64.8	58.8	49.8

Dimensions (Inches)

A	B	C	D	E	F	G	H	I	J	K	L	M	N	O	P	Q	R	S	T	U	V	W	X	Y
20	30.88	31.31	25.94	2	14	15.5	18.5		15.5	19.75														

Note: Accessories may effect dimensions shown.

Avg. Shipping Weight (Lbs)*: 126

*Includes fan, motor, and packaging.

Accessories:

DP STXB14 1/4HP 926-1150RPM (1/2) • LABEL UL/CUL 705 LISTED POWER VENT (709J) • AMCA-B SPARK RESISTANT KIT SDB/STXB • BIRD SCREEN, STXB/STXD 12-14 MOUNTED •

Submittal Notes:

