



S&P USA

Qty:	1
Tag:	
Project:	Explosion Proof Roof Exhaust

STXB18-1

Centrifugal Roof Exhauster-Belt Drive Upblast

STANDARD FEATURES:

Heavy Gauge Aluminum Construction • Non-Overloading Aluminum Curved Backward Inclined Wheel • Drives Sized for a Minimum of 150% of Drive Horsepower • Heavy Duty 200,000 Hour Rated Pillow Block Bearings • Quick-Release latches on motor cover for easy access to motor compartment • Lift lugs for easy and safe placement of the fan on the roof • Integral Deep Spun Inlet • Disconnect standard with ODP and TE single speed motors • AMCA Air and Sound Licensed • cULus 705 Certified • 5 Year Fan and 1 Year Motor Warranty •

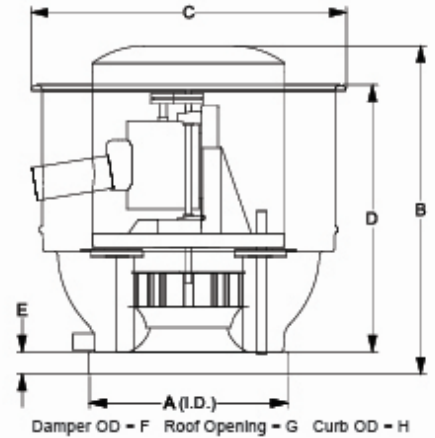

Performance

Fan RPM	Flow (CFM)	SP (in W.G.)	Power (HP)	SE	TE	FPM (TS)	FPM (OV)
1199	4500	.25	1.043	17%	30%	5964	1772

Altitude (Feet): n/a Temperature (Fahrenheit): n/a Density (Lb/Ft3): .075

Motor Information: (Wired for 115V)

HP	RPM	Volts/PH/Hz	Enclosure	Efficiency	Mounted
1	1725	115V/230V/1PH/60HZ	EXPLOSION PROOF	STANDARD	YES

Sound Power Levels - Octave Bands

LwA	DBA	Sone	1	2	3	4	5	6	7	8
80.5	69.0	19.5	85.8	88.7	81.2	77.5	72.6	71.1	67.2	66.5

Dimensions (Inches)

A	B	C	D	E	F	G	H	I	J	K	L	M	N	O	P	Q	R	S	T	U	V	W	X	Y
30	35.75	42.63	30.5	2	24	25.5	28.5		22.5	29.75														

Note: Accessories may effect dimensions shown.

Avg. Shipping Weight (Lbs)*: 171

*Includes fan, motor, and packaging.

Accessories:

DP STXB18 1HP 1001-1250RPM (5/8) • LABEL UL/CUL 705 LISTED POWER VENT (709J) • AMCA-B SPARK RESISTANT KIT SDB/STXB • BIRD SCREEN, STXB 18 MOUNTED •

Submittal Notes:

