



**S&P USA**

Qty: 1  
 Tag:  
 Project: Explosion Proof Exhaust Fan  
 Optimizer Version 2.0  
 Printed: 2022-11-10

**STXB20-1.5**

**Centrifugal Roof Exhauster-Belt Drive Upblast**

**STANDARD FEATURES:**

Heavy Gauge Aluminum Construction • Non-Overloading Aluminum Curved Backward Inclined Wheel • Drives Sized for a Minimum of 150% of Drive Horsepower • Heavy Duty 200,000 Hour Rated Pillow Block Bearings • Lift lugs for easy and safe placement of the fan on the roof • Integral Deep Spun Inlet • Disconnect standard with ODP and TE single speed motors • AMCA Air and Sound Licensed • cULus 705 Certified • 5 Year Fan and 1 Year Motor Warranty

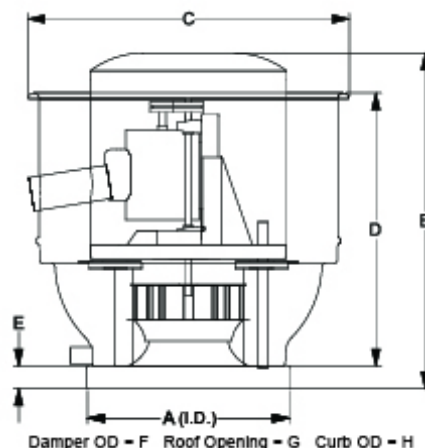

**Performance**

Fan RPM	Flow (CFM)	SP (in W.G.)	Power (HP)	FEP Actual (kW)	FEI	SE	TE	FPM (TS)	FPM (OV)
1061	5000	.25	1.016	1	0.89	19%	29%	5833	1386

Altitude (Feet): n/a      Temperature (Fahrenheit): n/a      Density (Lb/Ft3): .075

**Motor Information: (Wired for 230V)**

HP	RPM	Volts/PH/Hz	Enclosure	Efficiency	Mounted
1.5	1725	208V-230V/460V /3PH/60HZ	EXPLOSION PROOF	86.5%	YES

**Sound Power Levels - Octave Bands**

LwA	dBA	Sones	1	2	3	4	5	6	7	8
80	68	18.2	84	87	82	77	73	70	64	64

Dimensions (Inches)										
A	30.00	B	38.63	C	46.44	D	30.50	E	2.00	
F	24.00	G	25.50	H	28.50	I		J	22.50	
K	29.75	L		M		N		O		
P		Q		R		S		T		
U		V		W		X		Y		

Note: Accessories may effect dimensions shown.

Avg. Shipping Weight (Lbs)\*: 233

\*Includes fan, motor, and packaging.



in W.G.

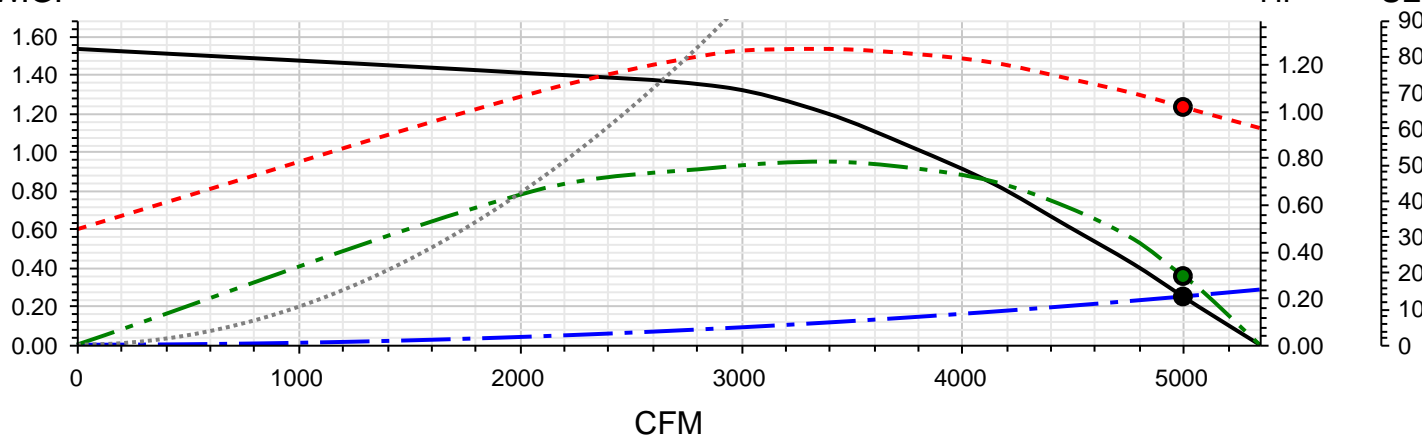

— Fan Curve    - - - System Curve    - - - Horsepower    - - - Static Efficiency    ..... Stall Curve

**Accessories:**

DP STXB20 1-1/2HP 1026-1175RPM (7/8) • LABEL UL/CUL 705 LISTED POWER VENT (709J) • AMCA-B SPARK RESISTANT KIT SDB/STXB • BIRD SCREEN, STXB 20-22 MOUNTED