

2

1

Single Panel Wall Shutters	
Part Number	Size (A)
WS-12	12"
WS-16	16"
WS-18	18"
WS-20	20"
WS-24	24"
WS-30	30"

Double Panel Wall Shutter	
Part Number	Size (A)
WS-36	36"
WS-42	42"
WS-48	48"
WS-54	54"
WS-60	60"

Blades

- 26 gauge 3105 mill finish aluminum.
- Galvanized reinforcement strip across top of blade for added strength and counter balancing and efficiency.
- Felt seal on leading edge of blade for tight closure and quiet operation.
- Flanged ends of blades provide additional weather seal protection.
- Center-mounted galvanized steel tie-rod connects blades for uniform opening and closing.
- 304 stainless steel pivot pins, rivets and bushings.
- Opens freely to allow full 90 degree opening and closing.

Frame

- .062 mill finish 6063 extruded aluminum.
- Welded corners provide rigidity and durability.
- Integrated weather stripping incorporated into frame for additional strength and weather protection.

Notes

Single Panel: 12"-30"
Double Panel: 36"-60"

Shutter should be mounted 1/3 the diameter of fan propeller away from propeller.

Maximum recommended velocity is 2,500 FPM of free area

Temperature - -40°F to 180°F

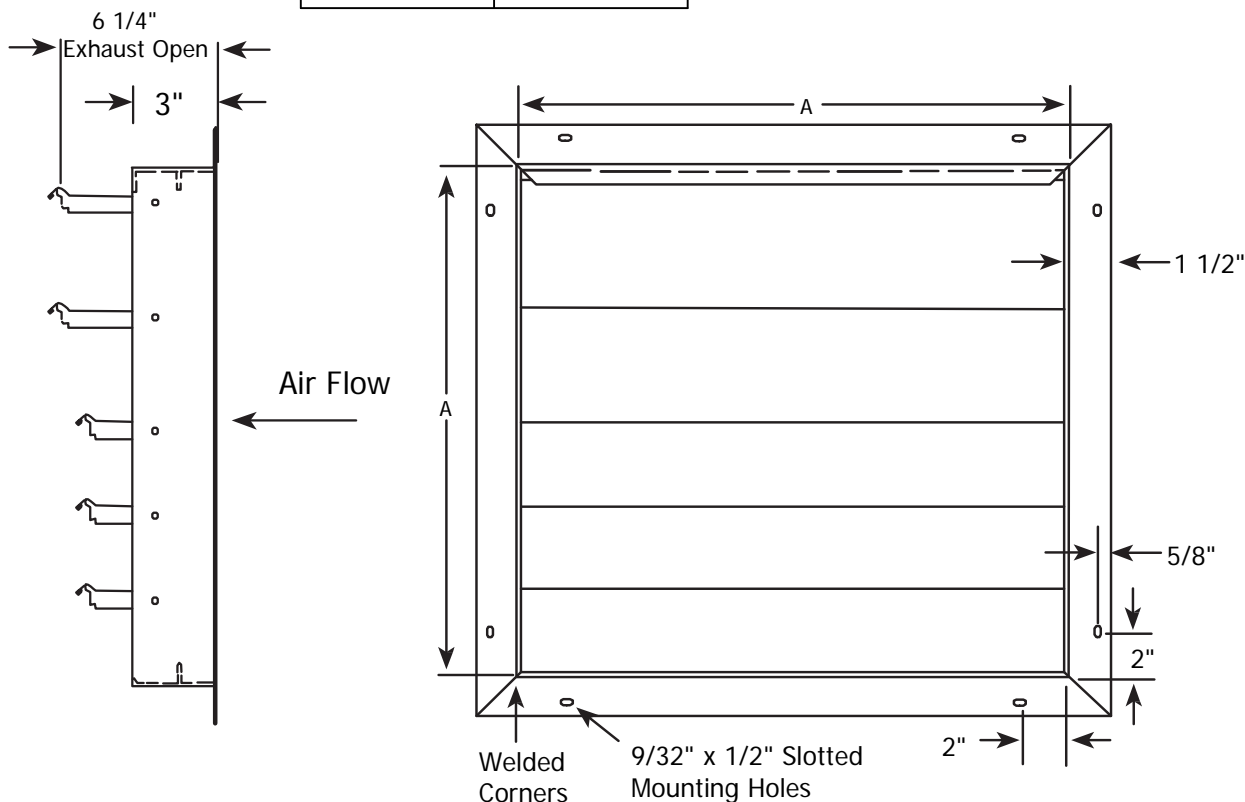

Americraft Manufacturing Co.
7937 School Rd.
Cincinnati, OH 45249
513-489-1047
www.americraftmfg.com

All Dimensions are in INCHES, unless noted.

Tolerances:
Fraction +/- .031
x.x +/- .031
x.xx +/- .020
x.xxx +/- .010

DRAWN BY:

D Giblin

DATE:

111014

PART NUMBER:

WS-12-60

REV

A

2

1